

Closed Unit Assembly

Note: For welded upright assemblies (end or intermediate), skip steps 1 and 2.

1 End upright assembly

End upright assembly requires one Angle post at the back and one Angle, Beaded or Delta post at the front. Bolt end panels inside the two posts as shown in (Fig. 3). Nuts and bolts should be located approximately 18" apart. Panels are typically provided in 2 or more pieces and overlap a minimum of 1".

2 Intermediate upright assembly

Intermediate upright assembly requires two Angle posts at the back, and two Angle or one Beaded or Delta post at the front. Bolt the end panel between Angle posts or between rear flanges on Beaded or Delta post. Note: Before deciding where bolts should be located when attaching panels to posts, a sample unit may be built with all shelves in place to determine optimal location to prevent the bolts from interfering with the shelves.

3 Bolt the top shelf to the upright assemblies through the top round hole of the post (Fig. 3). Bolt the bottom shelf to the upright using the third hole from the bottom of the post or other location where the bottom shelf will be required (3" max. from floor). Use two end upright assemblies if installing only one unit, or one end and one intermediate upright assembly if installing two or more units to form a row. For 18-gauge shelves and non-seismic applications, clips may be used instead of bolts on top and bottom shelves.

4 Install intermediate shelves using four clips per shelf. Shelves are adjustable on 1 1/2" centers using square cutouts on the posts for clip attachment.

5 Bolt the back panel to the back of the unit outside of the posts. If installing back to back units, the back panel should be placed between the units. Panels are typically provided in 2 or more pieces and overlap a minimum of 1".

6 Additional shelving units may be added to form a row by holding in position another intermediate upright assembly and repeating steps 3 through 5. For the last adder unit, use an end upright assembly instead of an intermediate assembly to finish the row.

7 If the bottom shelf must be less than 3" from the floor (to the bottom of the shelf), then the top and bottom shelves should be attached while the unit is on its back (Fig. 3). For adder units using Delta or Beaded posts with the bottom shelf less than 3" from floor, the top and bottom shelves must be attached to entire row before standing units upright.

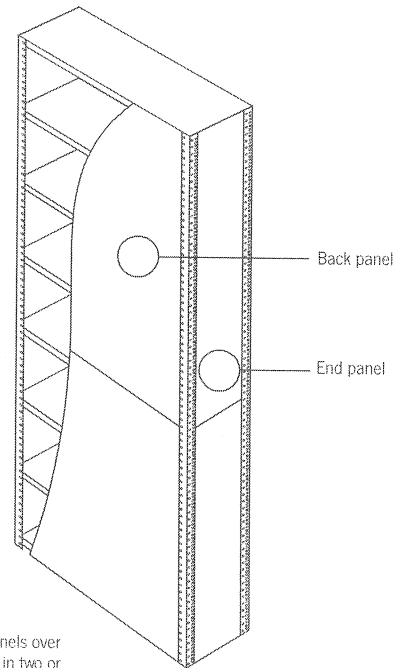

Fig. 4

End and back panels over 97" are supplied in two or more pieces

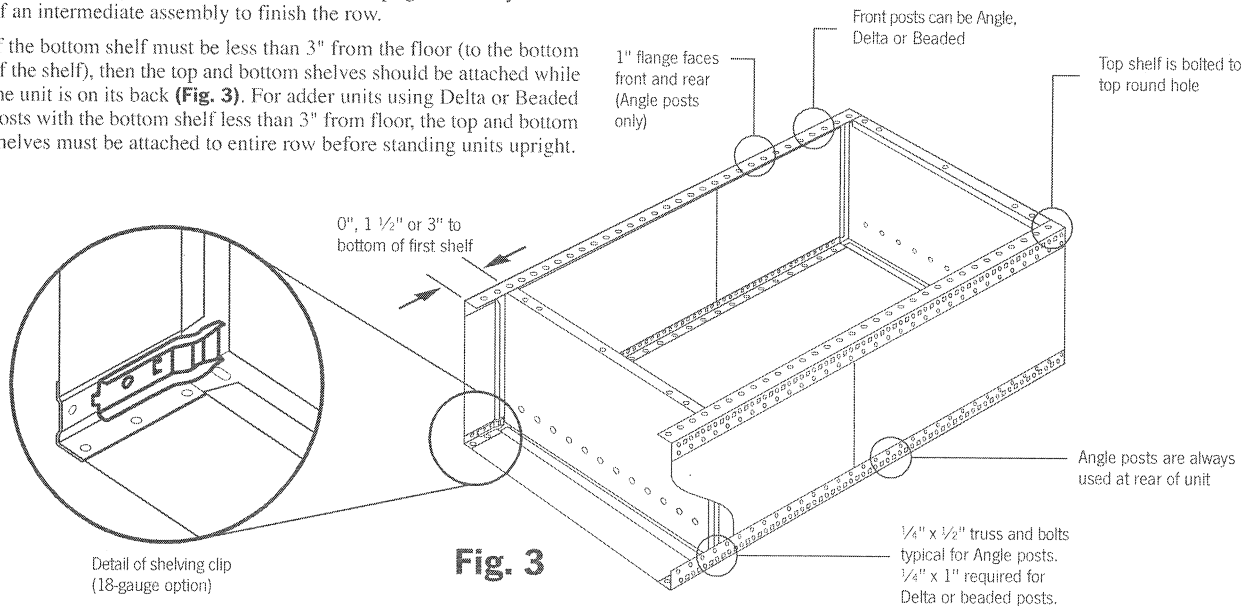

Fig. 3

Detail of shelving clip
(18-gauge option)

0", 1 1/2" or 3" to
bottom of first shelf

1/4" x 1/2" truss and bolts
typical for Angle posts.
1/4" x 1" required for
Delta or beaded posts.